

Job Name:

System Reference:

Date:

Indoor Unit:

PCA-A24KA7

Outdoor Unit:

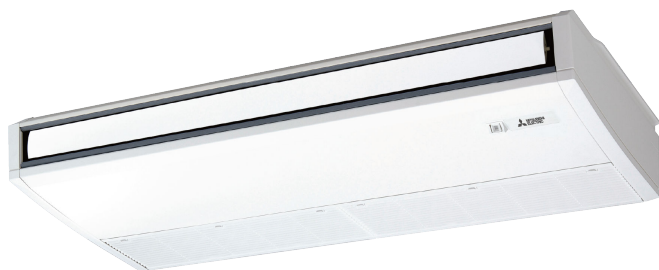
 PUZ-A24NHA7 PUZ-A24NHA7-BS**INDOOR UNIT FEATURES**

- Airflow settings for high and low ceiling applications
- Knock-out for outside-air intake
- Optional i-see Sensor™ for air distribution and energy saving
- Auto fan speed mode
- Filter status indicator
- Easy-to-clean, washable filter
- Suspends from ceiling for quick and easy installation
- Ideal for larger retail stores, classrooms, and restaurants

**OUTDOOR UNIT FEATURES**

- Variable speed INVERTER-driven compressor
- Suction accumulator pre-charged with refrigerant volume for piping length up to 100 ft (70 ft. for A12/18/24/30)
- 24-hour continuous operation (cooling mode)
- High pressure protection
- Fast restart due to bypass valve make it ideal for equipment cooling applications, such as data centers
- Superior energy and operational efficiency

## SPECIFICATIONS: PCA-A24KA7 & PUZ-A24NHA7(-BS)

Model number	Indoor unit		PCA-A24KA7
	Outdoor unit		PUZ-A24NHA7
			PUZ-A24NHA7-BS
Cooling*1	Maximum Capacity	Btu/h	24,000
	Rated Capacity	Btu/h	24,000
	Minimum Capacity	Btu/h	10,000
	Maximum Power Input	W	1,960
	Rated Power Input	W	1,960
	Moisture Removal	Pints/h	5.80
	Sensible Heat Factor		0.73
	Power factor	%	94.70
Heating at 47° F*2	Maximum Capacity	Btu/h	28,000
	Rated Capacity	Btu/h	26,000
	Minimum Capacity	Btu/h	8,800
	Maximum Power Input	W	2,230
	Rated Power Input	W	1,800
	Power factor	%	94.30
Heating at 17° F *3	Maximum Capacity	Btu/h	17,900
	Rated Capacity	Btu/h	15,400
	Maximum Power Input	W	1,770
	Rated Power Input	W	1,700
Efficiency	SEER		21.20
	EER *1		12.20
	HSPF (IV)		10.80
	COP at 47° F *2		4.23
	COP at 17° F *3		2.65
Electrical	Voltage, Phase, Frequency		208 / 230V, 1-phase, 60 Hz
	Guaranteed Voltage Range	V AC	187 - 253
	Voltage: Indoor - Outdoor, S1-S2	V AC	208V / 230
	Voltage: Indoor - Outdoor, S2-S3	V DC	24
	Voltage: Indoor - Remote controller	V DC	12
	Recommended Fuse/Breaker Size	A	25
	Recommended Wire Size (Indoor - Outdoor)	AWG	14
Indoor unit	MCA	A	1.00
	Fan Motor Full Load Amperage	A	0.54
	Fan Motor Output	W	95

## SPECIFICATIONS: PCA-A24KA7 & PUZ-A24NHA7(-BS)

Model number	Indoor unit		PCA-A24KA7
	Outdoor unit		PUZ-A24NHA7
			PUZ-A24NHA7-BS
	Airflow Rate, Dry	CFM	530-565-600-670
	Airflow Rate, Wet	CFM	495-530-565-635
	External Static Pressure	in.WG	n/a
	Sound Pressure Level	dB(A)	33-35-37-40
	Drain Pipe Size	In. (mm)	1-1/32 (26)
	Heat Exchanger Type		Plate fin coil
	External Finish Color		White Munsell 6.4Y 8.9/0.4
	Unit Dimensions	W: In. (mm)	50-3/8 (1280)
		D: In. (mm)	26-3/4 (680)
		H: In. (mm)	9-1/16 (230)
	Package Dimensions	W: In.	53-2/16
		D: In.	29-15/16
		H: In.	12-10/16
	Unit Weight	Lbs. (kg)	71 (32)
	Package Weight	Lbs.	82
Indoor unit operating temperature range	Cooling Intake Air Temp (Maximum / Minimum)	°F	90 DB, 73 WB / 66 DB, 59 WB
	Heating Intake Air Temp (Maximum / Minimum)	°F	82 DB / 50 DB
Outdoor unit	MCA	A	19
	MOCP	A	26
	Fan Motor Full Load Amperage	A	0.4
	Fan Motor Output	W	86
	Airflow Rate	CFM	1,940
	Refrigerant Control		Electronic Expansion Valve
	Defrost Method		Reverse Cycle
	Heat Exchanger Type		Cross fin
	Sound Pressure Level, Cooling*1	dB(A)	47
	Sound Pressure Level, Heating*2	dB(A)	48
	Compressor Type		INVERTER-driven twin rotary
	Compressor Model		SNB172FVHM1
	Compressor Rated Load Amps	A	7
	Compressor Locked Rotor Amps	A	11
	Compressor Oil Type // Charge	oz.	FV50S // 23

## SPECIFICATIONS: PCA-A24KA7 & PUZ-A24NHA7(-BS)

Model number	Indoor unit		PCA-A24KA7
	Outdoor unit		PUZ-A24NHA7
			PUZ-A24NHA7-BS
	External Finish Color		Ivory Munsell 3Y 7.8/1.1
	Base pan heater		n/a
	Unit Dimensions	W: In. (mm)	37-13/32 (950)
		D: In. (mm)	13 + 1-3/16 (330 + 30)
		H: In. (mm)	37-1/8 (943)
	Package Dimensions	W: In.	40-15/16
		D: In.	17-11/16
		H: In.	40-11/16
	Unit Weight	Lbs.	153 (69)
	Package Weight	Lbs.	112 (51)
Outdoor unit operating temperature range	Cooling Intake Air Temp (Maximum / Minimum)	°F	115 DB / 0* DB
	Heating Intake Air Temp (Maximum / Minimum)	°F	70 DB, 59 WB / -4 DB, -4 WB
	Thermal Lock-out / Re-start Temperatures**	°F	-8 / -4 DB
Refrigerant	Type		R410A
	Charge	Lbs, oz	7 lbs, 11 oz
Piping	Gas Pipe Size O.D. (Flared)	In.(mm)	5/8 (15.88)
	Liquid Pipe Size O.D. (Flared)	In.(mm)	3/8 (9.52)
	Maximum Piping Length	Ft. (m)	165 (50)
	Maximum Height Difference	Ft. (m)	100 (30)
	Maximum Number of Bends		15

AHRI Rated Conditions (Rated data is determined at a fixed compressor speed)	*1 Cooling (Indoor // Outdoor)	°F	80°F DB, 67°F WB // 95°F DB, 75°F WB
	*2 Heating at 47°F (Indoor // Outdoor)	°F	70°F DB, 60°F WB // 47°F DB, 43°F WB
	*3 Heating at 17°F (Indoor // Outdoor)	°F	70°F DB, 60°F WB // 17°F DB, 15°F WB
Conditions	*4 Heating at 5°F (Indoor // Outdoor)	°F	70°F DB, 60°F WB // -4°F DB, -5°F WB

### Notes

\*Wind baffles required to operate below 23°F DB in cooling mode. PUZ with wind baffle: 0°F - 115°F.

\*\*System cuts out in heating mode to avoid thermistor error and automatically restarts at these temperatures

## SPECIFICATIONS: PCA-A24KA7 & PUZ-A24NHA7(-BS)

### SEACOAST PROTECTION

External Outer Panel: Phosphate coating + Acrylic-Enamel coating

Fan Motor Support: Epoxy resin coating (at edge face)

Separator Assembly; Valve Bed: Epoxy resin coating (at edge face)

“Blue Fin” treatment is an anti-corrosion treatment that is applied to the condenser coil to protect it against airborne contaminants.

Notes:

## ACCESSORIES: PCA-A24KA7 & PUZ-A24NHA7(-BS)

PCA-A24KA7	
High Efficiency (MERV 8) Filter Element	<input type="checkbox"/> PAC-SH89KF-E
High Efficiency (MERV 8) Filter Element	<input type="checkbox"/> PAC-SE81KF-E
3-Pole Disconnect Switch (30A/600V/UL) [fits 2" X 4" utility box]	<input type="checkbox"/> TAZ-MS303
Drain Pan Level Sensor (Control for indoor unit shut off to prevent drain pan overflow)	<input type="checkbox"/> DPLS2
Advanced Blue Diamond Mini-Condensation pump w/ Reservoir & Sensor (110V)	<input type="checkbox"/> X87-711 - 110
Advanced Blue Diamond Mini-Condensation pump w/ Reservoir & Sensor (208/230V)	<input type="checkbox"/> X87-721 - 208/230
MegaBlue Blue Diamond Condensate Pump (110-230V)	<input type="checkbox"/> X87-835
i-see Sensor™	<input type="checkbox"/> PAC-SH91MK-E
External fan / Heater control relay adapter	<input type="checkbox"/> CN24RELAY-KIT-CM3
Backlit, wall-mounted, wireless	<input type="checkbox"/> MHK1
Wireless Remote Controller	<input type="checkbox"/> MRCH1
Wireless Receiver	<input type="checkbox"/> MFH1
Portable Central Controller	<input type="checkbox"/> MCCH1
Outside Air Sensor	<input type="checkbox"/> MOS1
Wireless adapter	<input type="checkbox"/> PAC-USWHS002-WF-1
BACnet® and Modbus Interface	<input type="checkbox"/> PAC-UKPRC001-CN-1
Wall-mounted, Wired	<input type="checkbox"/> PAC-YT53CRAU-J
Wired remote controller	<input type="checkbox"/> PAR-32MAA-J
Remote Controller Kit	<input type="checkbox"/> PAR-SL93B-E
Remote Controller Kit with i-see Sensor™	<input type="checkbox"/> PAR-SA92MW-E
T-STAT Interface	<input type="checkbox"/> PAC-US444CN-1
Wired remote controller	<input type="checkbox"/> PAR-32MAA
Simple remote controller	<input type="checkbox"/> PAC-YT53CRAU
Wireless Remote Controller	<input type="checkbox"/> PAR-FL32MA-E
Wire for Remote ON/OFF with CN32 connector	<input type="checkbox"/> PAC-715AD
Lockdown Bracket for wireless, hand-held, remote controllers	<input type="checkbox"/> RCMKP1CB

PUZ-A24NHA7(-BS)	
Twining Distribution Pipe (50:50)	<input type="checkbox"/> MSDD-50TR-E
Front Wind Baffle	<input type="checkbox"/> WB-PA5
Drain socket	<input type="checkbox"/> PAC-SG61DS-E
Centralized Drain Pan	<input type="checkbox"/> PAC-SG64DP-E
M-NET Converter	<input type="checkbox"/> PAC-SF83MA-E
Control/Service Tool	<input type="checkbox"/> PAC-SK52ST
Wall mounting bracket (powder-coated steel)	<input type="checkbox"/> QCWB2000M-1

## ACCESSORIES: PCA-A24KA7 & PUZ-A24NHA7(-BS)

PUZ-A24NHA7(-BS)	
Wall mounting bracket (316 Series Stainless Steel)	<input type="checkbox"/> QCWBSS
M-NET control adapter for Building Management System	<input type="checkbox"/> PAC-SF83MA-E
Outdoor Unit Mounting Pad 24" x 42" x 3"	<input type="checkbox"/> ULTRILITE2
Outdoor Unit 3-1/4 inch Mounting Base - Pair (Plastic)	<input type="checkbox"/> DSD-400N
MiniSplit Mounting Stand-Single Fan models - 12"	<input type="checkbox"/> QSMS1201M
MiniSplit Mounting Stand-Single Fan models - 18"	<input type="checkbox"/> QSMS1801M
MiniSplit Mounting Stand-Single Fan models - 24"	<input type="checkbox"/> QSMS2401M
3/8 x 5/8 x 10' / 1/2" Lineset (Twin-Tube Insulation)	<input type="checkbox"/> MPLS385812T-10
3/8 x 5/8 x 15' / 1/2" Lineset (Twin-Tube Insulation)	<input type="checkbox"/> MPLS385812T-15
3/8 x 5/8 x 30' / 1/2" Lineset (Twin-Tube Insulation)	<input type="checkbox"/> MPLS385812T-30
3/8 x 5/8 x 50' / 1/2" Lineset (Twin-Tube Insulation)	<input type="checkbox"/> MPLS385812T-50
3/8 x 5/8 x 65' / 1/2" Lineset (Twin-Tube Insulation)	<input type="checkbox"/> MPLS385812T-65
3/8 x 5/8 x 100' / 1/2" Lineset (Twin-Tube Insulation)	<input type="checkbox"/> MPLS385812T-100

# DIMENSIONS: PCA-A24KA7 & PUZ-A24NHA7 (-BS)

## PCA-A24KA7

Unit: inch (mm)

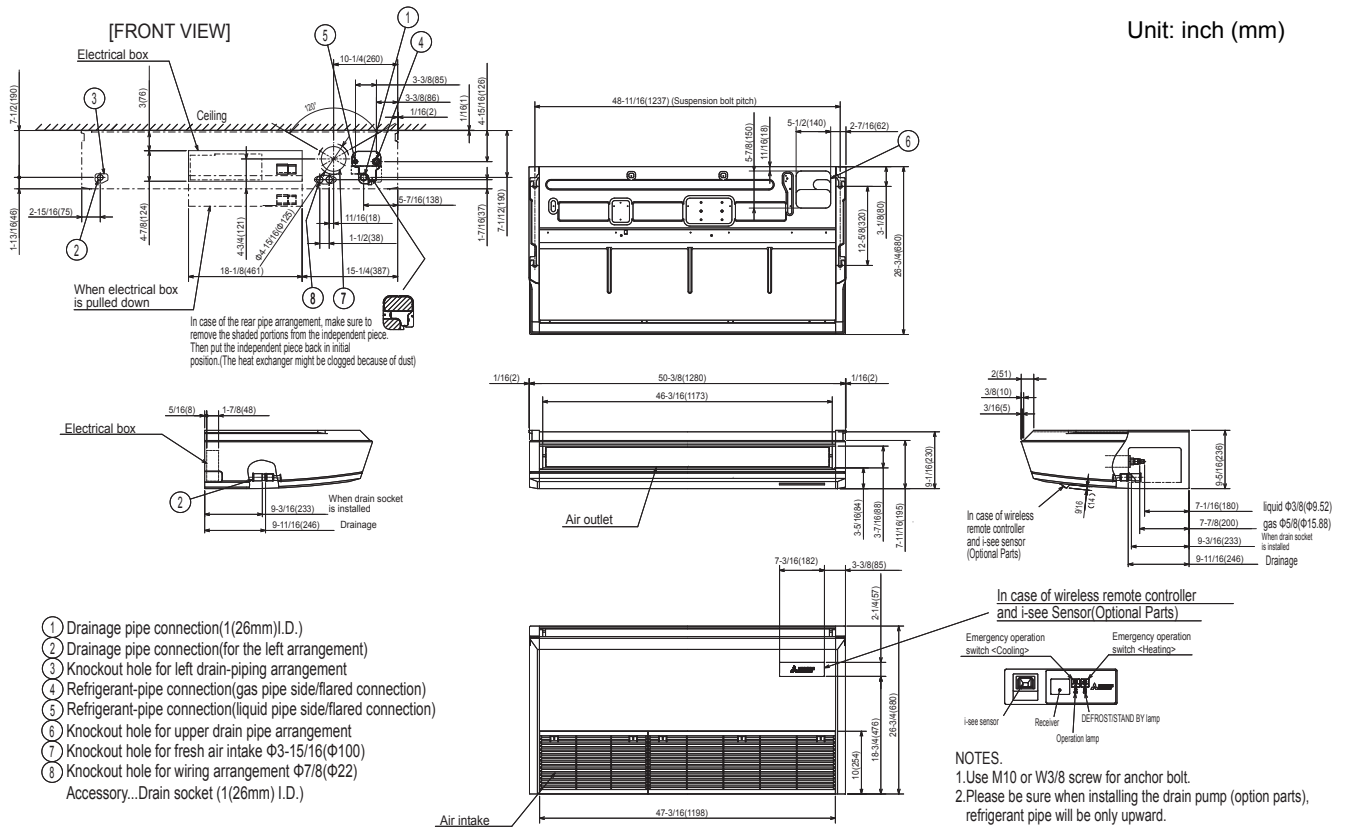



# DIMENSIONS: PCA-A24KA7 & PUZ-A24NHA7 (-BS)

## PUZ-A24NHA7(-BS)

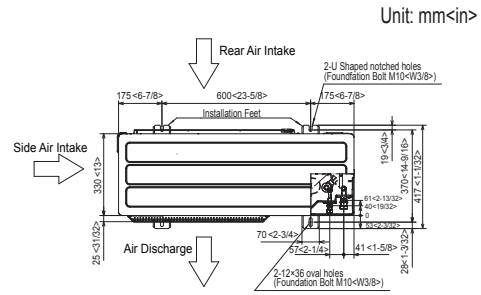
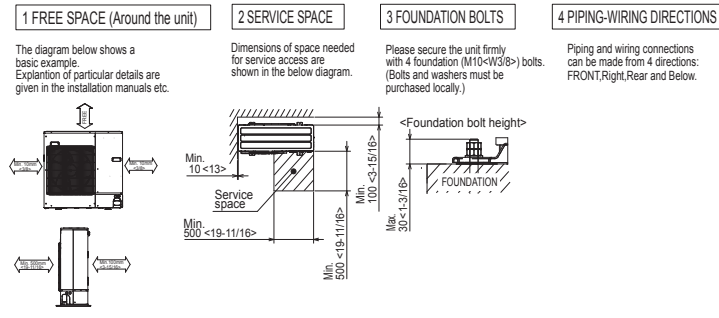

**Example of Notes**

- ① -- Refrigerant GAS pipe connection (FLARE)  $\phi 15.88(5/8\text{F})$
- ② -- Refrigerant LIQUID pipe connection (FLARE)  $\phi 9.52(3/8\text{F})$
- \*1-- Indication of STOP VALVE connection location.

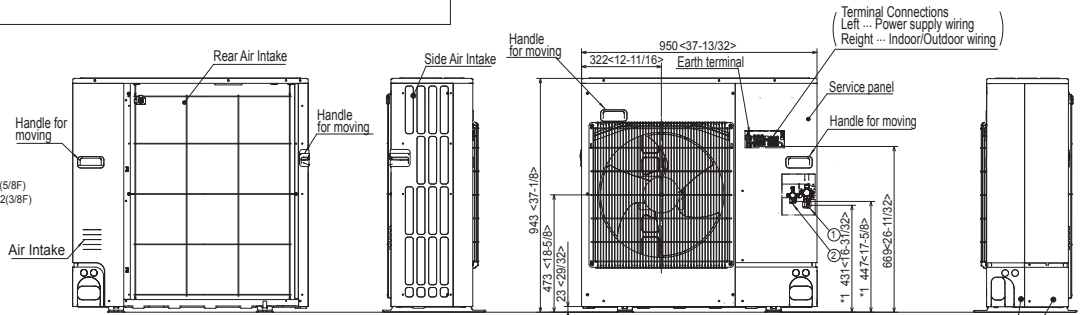

**Piping knockout Hole Details**

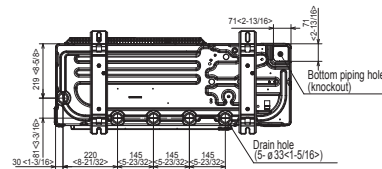
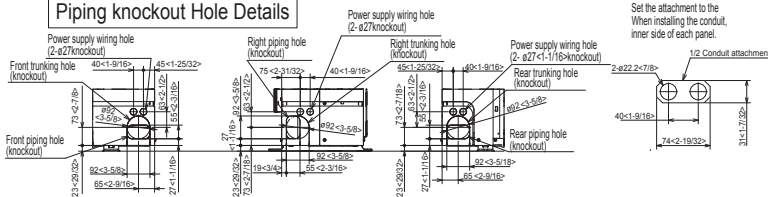

**COOLING & HEATING**

1340 Satellite Boulevard, Suwanee, GA 30024  
Toll Free: 800-433-4822 [www.mehvac.com](http://www.mehvac.com)



FORM# PCA-A24KA7 / PUZ-A24NHA7(-BS) - 201702

Specifications are subject to change without notice.

Copyright © 2017 Mitsubishi Electric US, Inc.